

WATER PUMP TECHNICAL SUPPORT BOOK

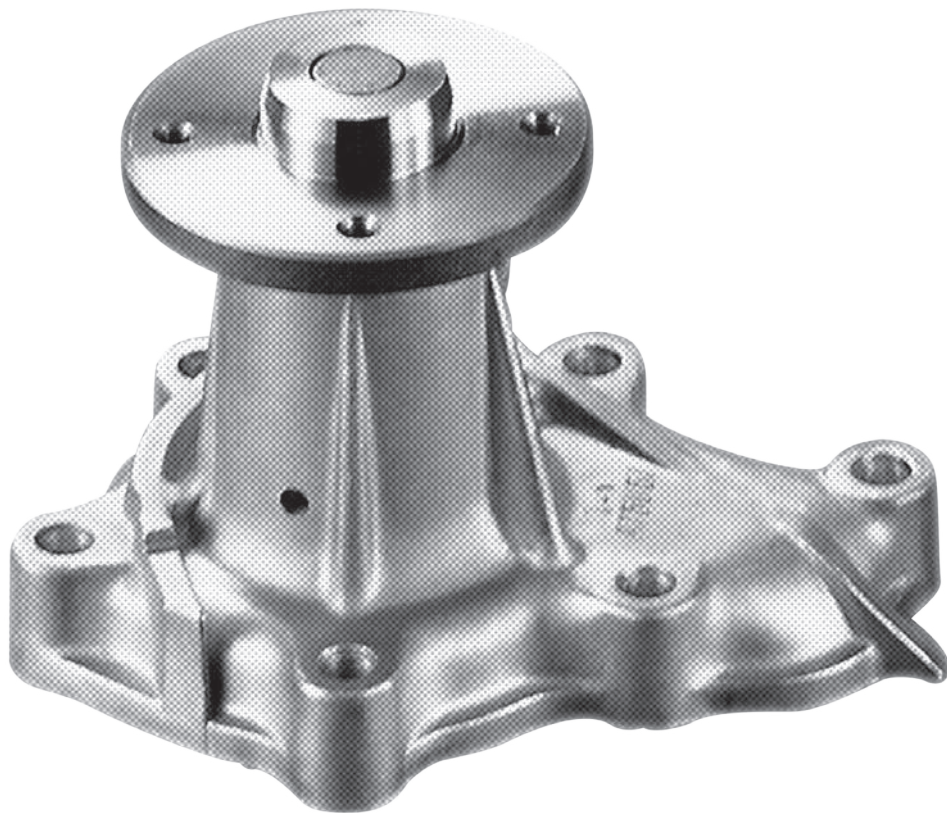

CONTENTS



What is a water pump?

- What is a water pump? Page 01
- What is coolant? Page 02
- Mechanical seal Page 03–04
- Water pump bearing Page 05
- Gasket and O-ring Page 06



Technical support

- For safe use Page 07–08
- Failure symptom - Occurrence cause chart Page 09–11
 - Coolant leak Page 09
 - Abnormal noise Page 10
 - Other Page 11
- Replacement necessity diagnostic chart Page 12



Failure example cases

- Example cases of failure Page 13–22
 - Coolant leak Page 13–17
 - Abnormal noise Page 18–20
 - Peripheral parts Page 21
 - Glossary Page 22



What is a water pump?

What is a water pump?

Role

The water pump is mounted in the front of the cylinder block for the water-cooled engine, and it forcibly circulates the coolant to maintain an adequate engine temperature.

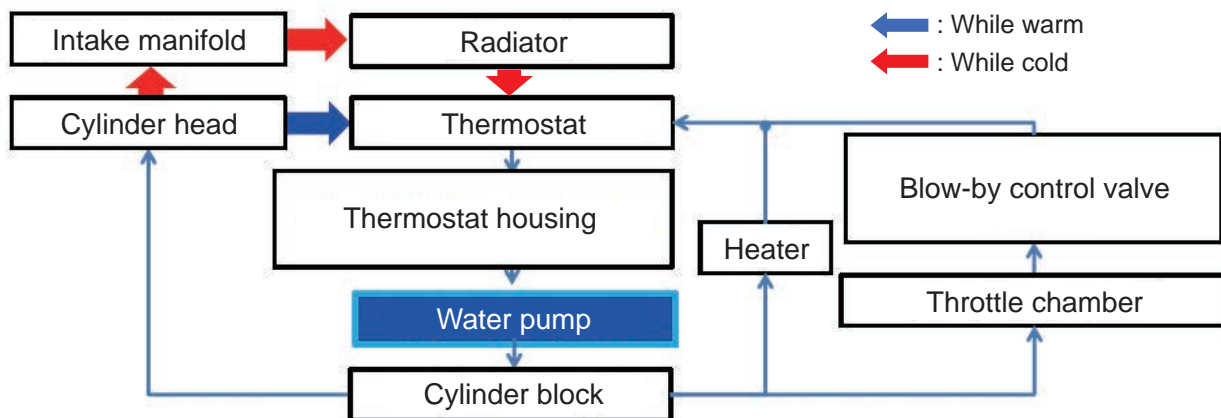

Structure

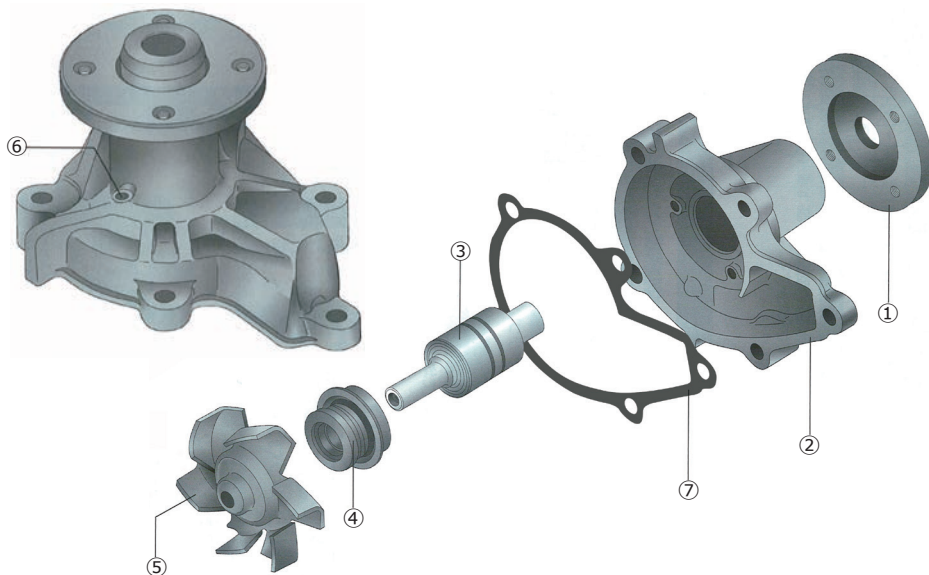

Components

- ① Hub
- ② Body
- ③ Bearing
- ④ Mechanical seal
- ⑤ Impeller
- ⑥ Drain hole
- ⑦ Gasket

What is coolant?

Role of coolant

The temperature inside the combustion chamber of the car engine can reach 2,000–3,000°C, and the coolant works to maintain the hot engine within an appropriate temperature range.

To attain an extended period of use, prevention of corrosion, deterioration, and rust with metals and rubbers comprising the cooling system as well as providing anti-freezing and defoaming effects are necessary.

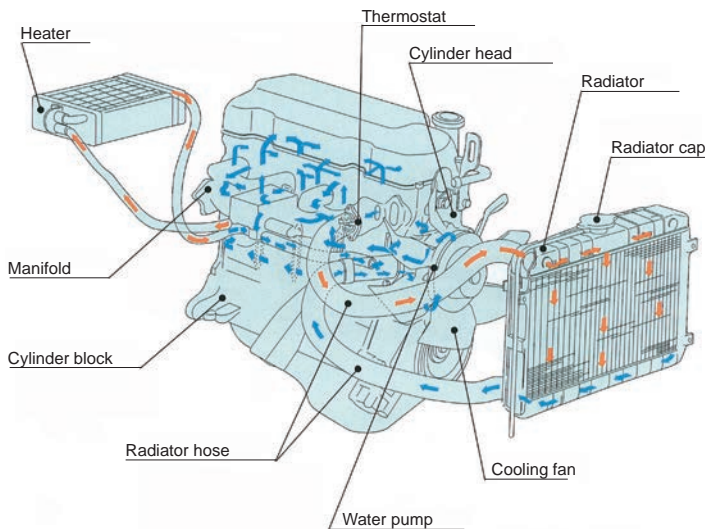

Function of each part in cooling path

- **Water jacket**
Coolant path inside the engine
- **Radiator**
Dissipates heat from coolant
- **Radiator cap**
Acts as a lid for coolant supply port and regulates the cooling system pressure
- **Cooling fan**
Draws in air at the back of radiator
- **Water pump**
Forcibly circulates coolant
- **Thermostat**
Changes path and flow rate of coolant according to coolant temperature
- **Radiator hose**
Path between radiator and engine

Mechanism of coolant circulation

The engine revolution is input via the water pump pulley and hub, and the centrifugal force generated by the rotating impeller is transferred to the coolant flow through the volute chamber diffuser.

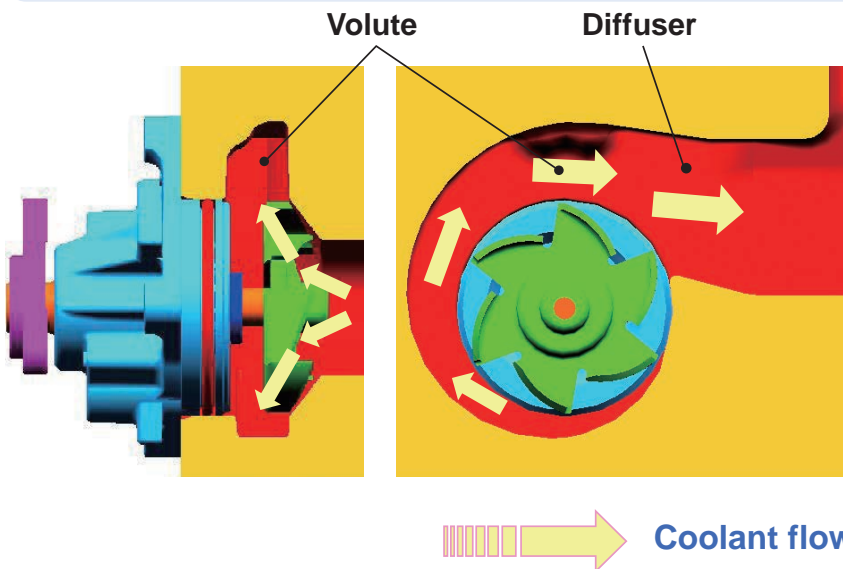

- **Volute**
Guides the coolant flow out of the impeller in a fixed direction
- **Diffuser**
Converts the coolant velocity energy to a pressure that allows coolant circulation against the cooling path resistance

Mechanical seal

Role

Attached to the bearing shaft and body, the mechanical seal serves to seal the gap between the rotating part and the fixed end such that coolant in the pump chamber does not leak out.

Mechanical seal assembled state

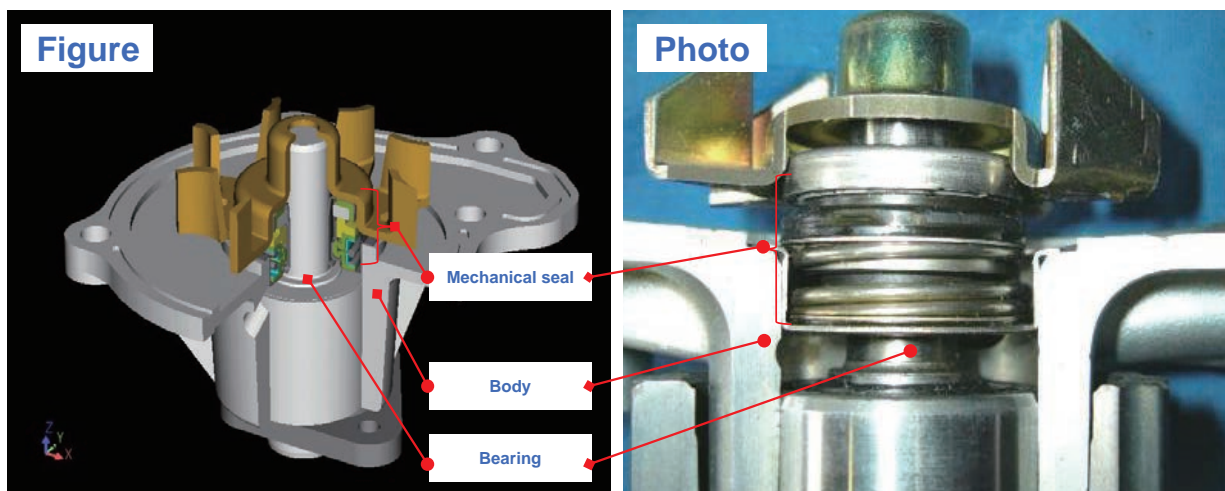

Mechanical seal composition

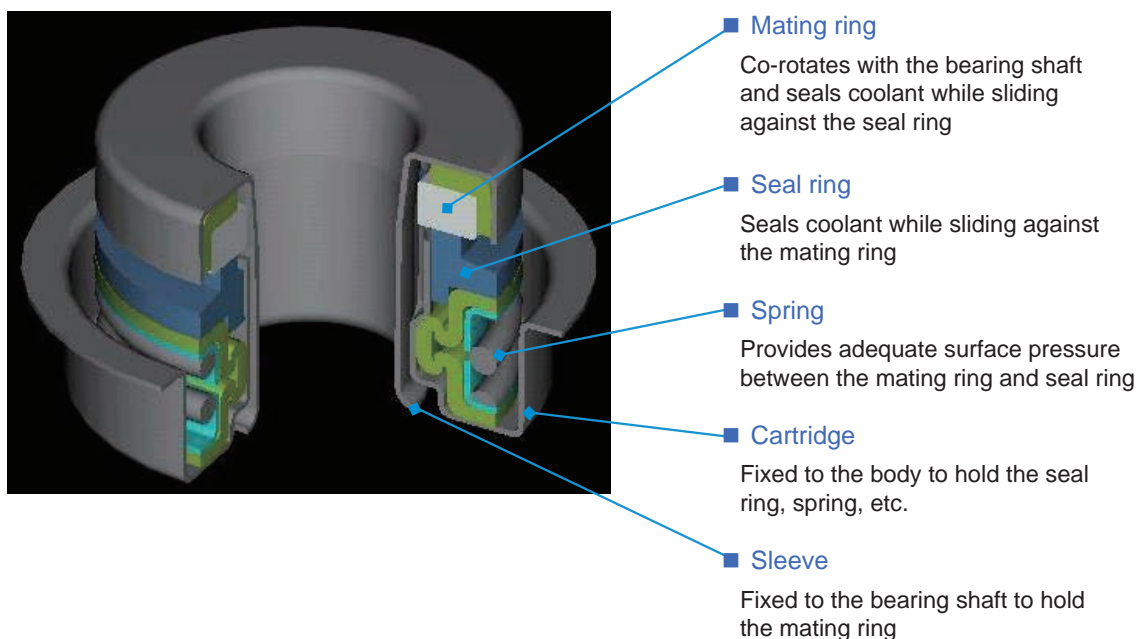

Working mechanism

When the engine is running, a fine liquid film is formed on the sliding surface (between seal and mating rings) owing to the rotating mechanical seal.

Surface tension prevents leakage while in the liquid state. However, as sliding occurs owing to high-speed rotation during running, the liquid temperature on the seal surface increases and vapor is generated.

Moreover, an intrusion of contaminant onto the sliding surface can weaken the surface tension, leading to a possible coolant leak.

Consequently, a very small amount of coolant may ooze out (to bearing side).

The water pump is provided with a vapor hole at the top and a drain hole at the bottom to prevent the coolant from entering into the bearing.

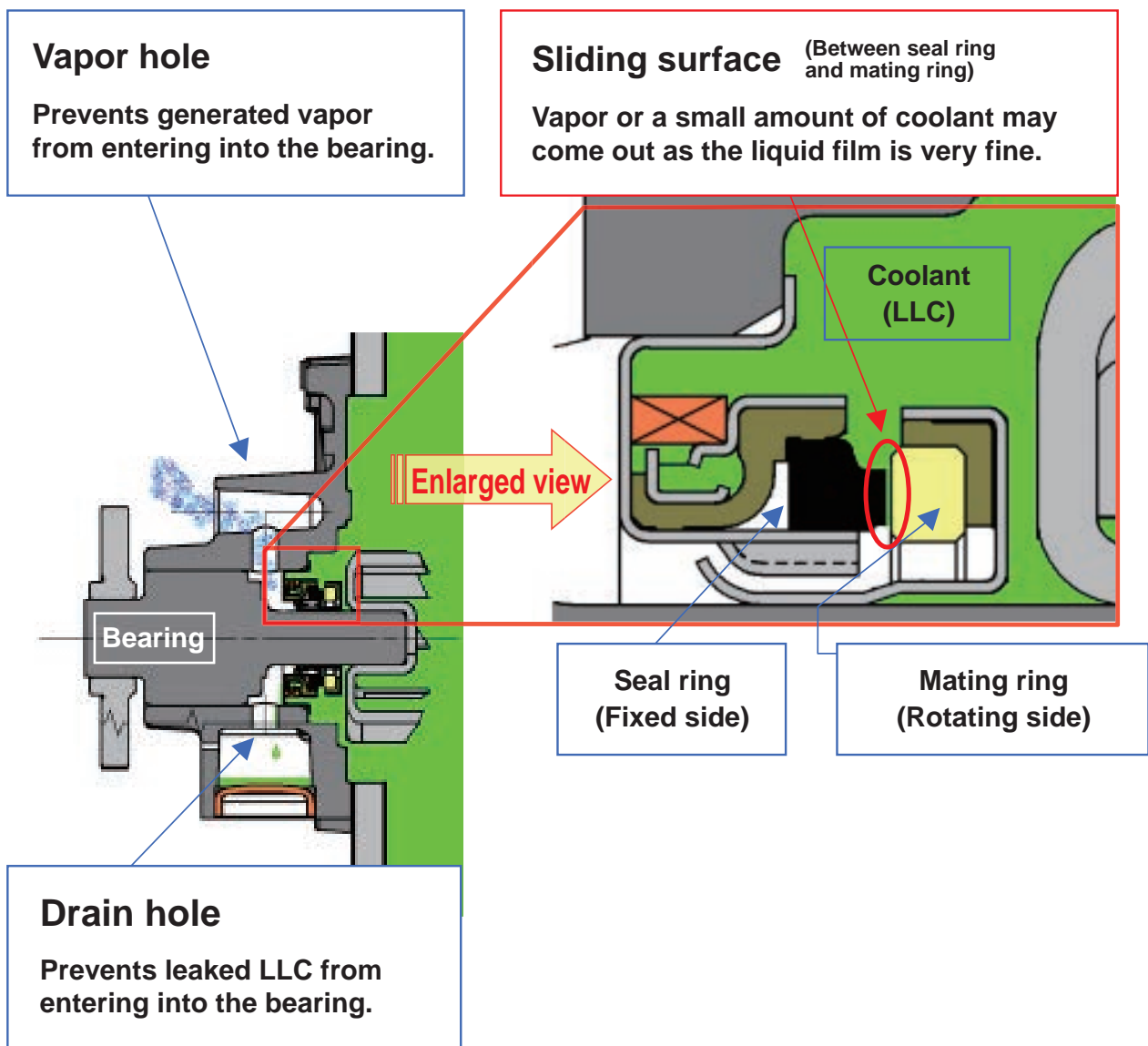

Water pump bearing

Role

It is a component that receives input load and transmits smooth rotation to the impeller via the pulley and hub. The water pump bearing is equipped with two rows of multiple rolling elements, which work to collectively receive the load of the belt, fan, fan coupling, etc. Two different types of bearing are adopted according to the extent and position of the load—one employing balls in both rows and another employing rollers in one row. As bearings have specified receivable loads corresponding to the size, a bearing damage (causing abnormal noise and locking) can result from excessive belt tension and excessive deflection of fan coupling.

Composition of water pump bearing

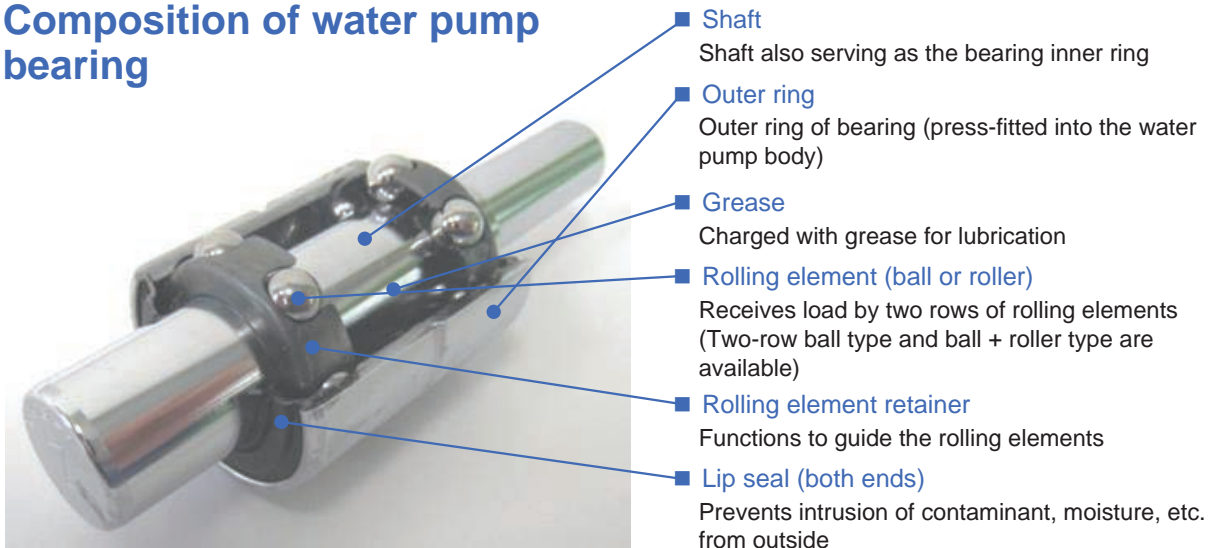

Receiving load by two rows of rolling elements

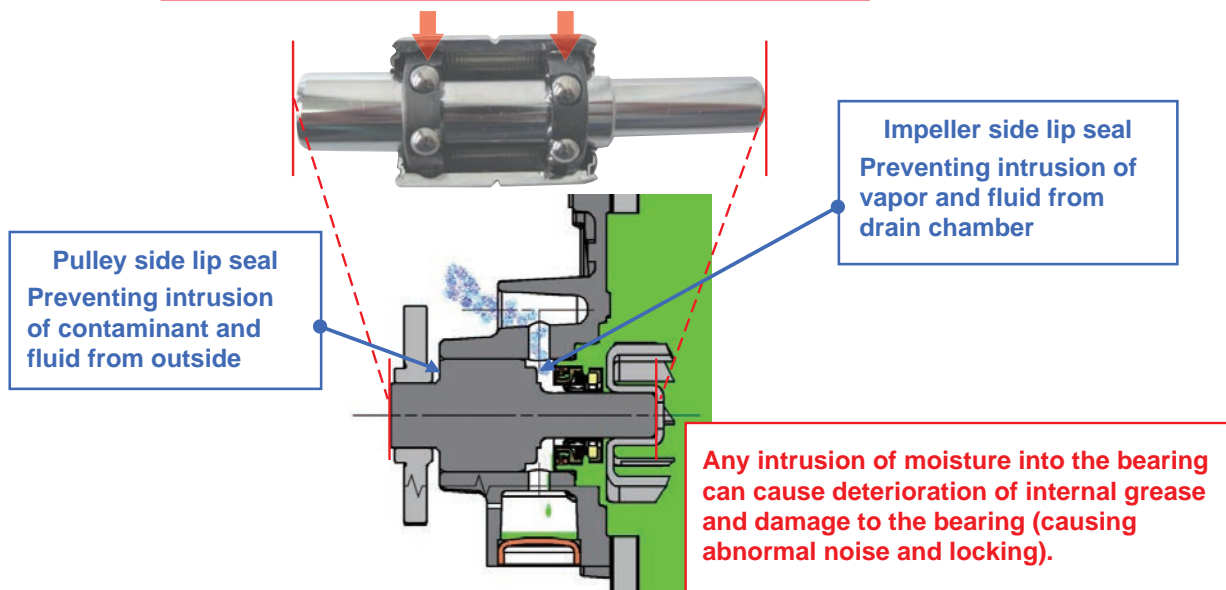

Gasket and O-ring

Role

Gasket and O-ring work to seal the water pump and mating parts from elements such as the coolant.

*Hitachi Water Pump comes with a gasket even when the water pump (genuine part) in the vehicle assembled state employs the liquid gasket. Please use the gasket provided when replacing.

About liquid gasket (FIPG)

In the production line, stringent control on the application amount is implemented by the use of components including an FIPG applicator.

In addition, attention is necessary for replacement because installation time constraints and the curing time after application must be considered.

Therefore, Hitachi Water Pump is provided with gasket to improve the work efficiency and prevent failures associated with liquid gasket.

(Reference)

■ Liquid gasket applicator



■ Example of maintenance procedures (Excerpts)

Apply seal packing (diameter of 2.2–2.5 mm) along the outside of the water pump groove.

■ Caution ■

- Degrease the mounting surface.
- Assemble within 5 min after application of seal packing.
- Do not start the engine before 2 h after installation.

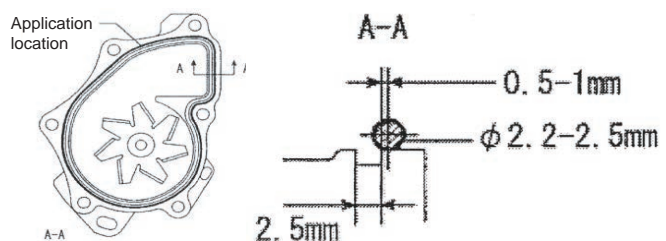

■ Example case where a liquid gasket was applied to the mounting surface, and extruding liquid gasket was caught in the mechanical seal

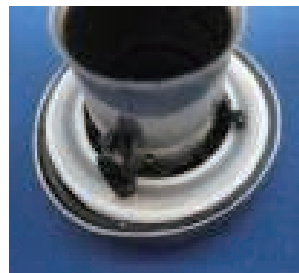
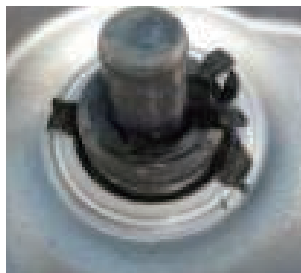



Technical support

For safe use

- 1 Do not use liquid gasket on the mounting surface (including gasket and O-ring).**

- See page 06 for details.

- 2 Thoroughly clean the mating mounting surface (rust, packing residue, etc.).**

- Prevents coolant leakage from the mounting surface.

- 3 Before replacing the pump, thoroughly clean the engine cooling path.**

Replace coolant two to three times (perform flushing) while using the old water pump to remove contaminants from the coolant path, and then replace with a new water pump.

- Prevents coolant leakage from the mechanical seal resulting from contamination by foreign matter.

- 4 After replacing the pump, replace the coolant (LLC).
*Ensure that LLC is used at the concentration specified by the car manufacturer (30-50%).**

- Degraded coolant (LLC) can cause various problems in the cooling system.

- 5** For the coolant, do not use anything other than LLC.
(Radiator leakage inhibitor, etc.)
- Any substance can become a contaminant in the coolant and cause issues due to consequent mechanical seal damage.
- 6** Ensure that the belt tension conforms to that specified by the car manufacturer.
(Check the auto tensioner for damage.)
- Any excess input can result in issues including failure of bearing parts (bearing and body).
- 7** Check the bearing components (bearing, etc.) of the auxiliary parts other than the water pump for any damage including looseness.
- Rattle from other auxiliary parts can propagate through the belt and generate vibration input, affecting the bearing parts (bearing, hub, and pulley).
- 8** Check the fan coupling for any damage including looseness.
(Bearing, etc.)
- If there is looseness with the fan coupling, eccentricity (large deflection) resulting from tip unbalance can lead to serious problems, such as failure of bearing parts (including the bearing and body).



Caution

**Any problem arising from water pump can hinder the driving of the vehicle.
Please observe the instructions provided. We also recommend regular inspections and early replacement.**

Failure symptom - Occurrence cause chart

Failure symptom: Coolant leak

Occurrence location	Failure part	Occurrence cause
CASE 1 From drain hole	Mechanical seal surface abrasion	Contaminants (e.g., dust, sludge, and rust) existing in the coolant were caught in the seal part, causing damage to the sliding part. <ul style="list-style-type: none"> Insufficient cleaning of coolant path Contamination of the coolant by radiator leakage inhibitor and other elements Bearing damage → Rattling → Looseness occurrence in seal parts on same axles
	Contaminant adhesion to mechanical seal	After an occurrence of contaminant adhesion onto the sliding surface or intrusion of elements such as liquid gasket and adhesive into the pump chamber, contaminant biting occurred in the seal part, resulting in separation. <ul style="list-style-type: none"> Coolant degradation Elution of members in the coolant path Excessive application of liquid gasket and adhesive Coolant charged before curing of liquid gasket Contamination of the coolant by radiator leakage inhibitor, etc.
	Cracking or burn with mechanical seal	Operated without coolant fed to the seal part, resulting in a heat shock after the seal sliding surface temperature became high. <ul style="list-style-type: none"> Operation performed while coolant level is low (insufficient air bleeding) Decrease in defoaming performance due to degraded coolant
CASE 2 From mounting surface	O-ring tear	Operation in abnormally high temperature environments Insufficient tolerance temperature
	O-ring seizure	Application of liquid gasket and adhesive Hardening due to aging
	Gasket and O-ring cracks	Contaminant biting during mounting (insufficient cleaning) Manufacturing defect
	Mounting surface fault	Insufficient tightening torque with the mounting bolt Faulty parallelism of the main body (manufacturing defect)
CASE 3 From main body	Erosion by cavitation (pitting)	Acidification and decrease in defoaming performance due to coolant degradation Coolant amount is insufficient (insufficient air bleeding) Faulty radiator cap
	Cavity	Manufacturing defect

Failure symptom: Abnormal noise

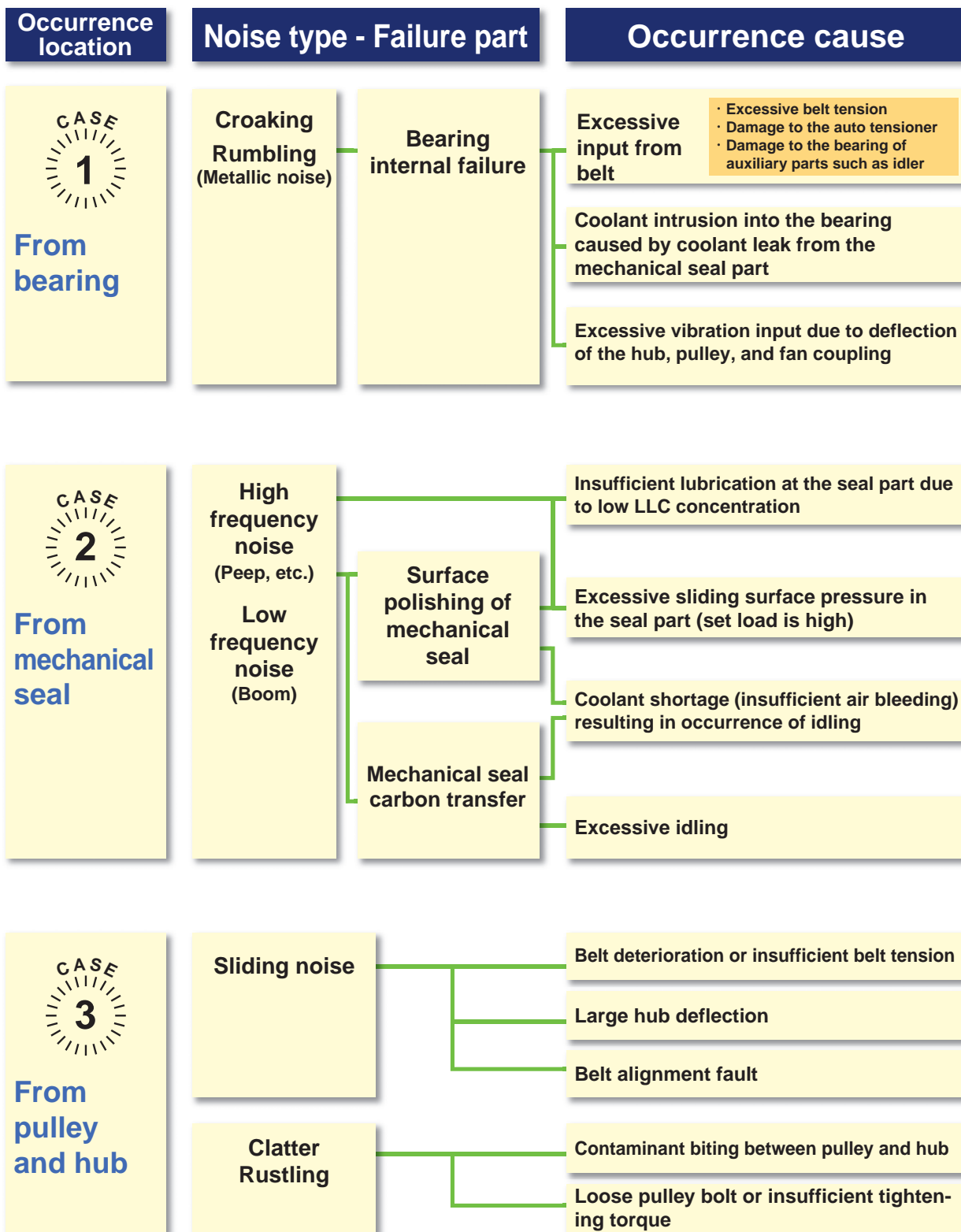

Other failure symptoms

Symptom	Occurrence location	Failure part	Occurrence cause
Impeller loss	Blade	Decreased thickness Blade wear	<ul style="list-style-type: none"> Corrosion due to coolant degradation (e.g., acidification and decrease in defoaming performance) and *cavitation Cavitation occurrence due to faulty radiator cap
Idling of impeller	Crimping part	Abrasion of impeller crimping part	<ul style="list-style-type: none"> Coolant degradation (acidification, decrease in defoaming performance) Corrosion due to faulty radiator cap and erosion by cavitation
	Press fitting part	Separation from bearing shaft	<ul style="list-style-type: none"> Manufacturing defect <ul style="list-style-type: none"> Insufficient press fitting force due to dimensional defect Slanted press fitting during assembly Coolant freezing
Body damage	Main body	Body breakage or damage	<ul style="list-style-type: none"> Excessive belt tension Occurrence of excessive vibration input caused by tip whirling resulting from fan coupling damage
Pulley hub separation	Pulley/hub Press fitting part	Pulley idling due to coming off of shaft	<ul style="list-style-type: none"> Excessive input from belt <ul style="list-style-type: none"> Excessive belt tension Damage to the auto tensioner Damage to the bearing of auxiliary parts such as idler Excessive vibration input due to deflection of the hub, pulley, and fan coupling Belt alignment failure resulting from slanting caused by contaminant biting between the pulley/hub and mounting surface Manufacturing defect <ul style="list-style-type: none"> Insufficient press fitting force due to dimensional defect Slanted press fitting during assembly

*Cavitation: See page 22

Replacement necessity diagnostic chart (coolant leak, abnormal noise)

When you suspect coolant leak or abnormal noise ...

Check the necessity for replacement according to the following sequence.

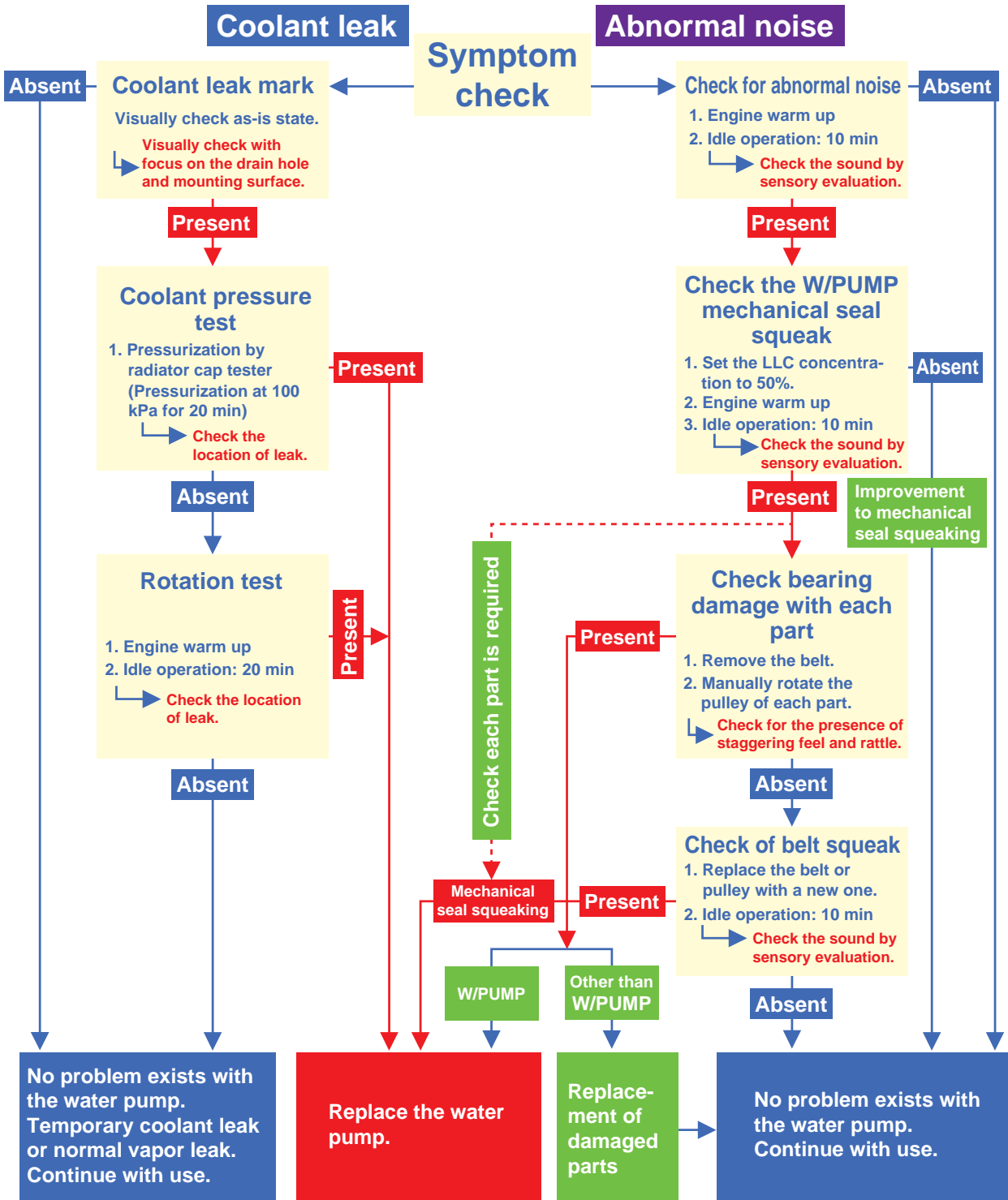



Failure example cases

Coolant leak

Coolant staining

Coolant circulates in the engine, and naturally becomes dirty as the operating time accumulates. For this reason, a periodic replacement is necessary as regular maintenance. However, when replacing the pump, it is additionally required to perform thorough cleaning and replace the entire volume of coolant with new one.

- If cleaning is not sufficient or the coolant is not replaced in its entirety, contaminants such as dust, sludge, and sand in the coolant path can be caught onto the mechanical seal sliding surface (seal surface), and coolant may leak from the drain hole resulting from a loss of sealing performance.

(1) Coolant contamination

Installed period: 3 days

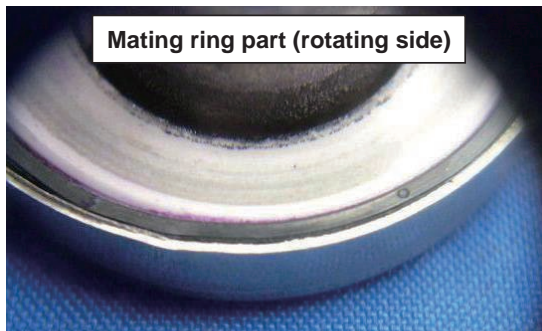

Mating ring part (rotating side)



Seal ring part (fixed side)

Coolant degraded owing to contamination

Travel distance: 5,000 km



Coolant degraded owing to contamination

(2) Contaminant biting in mechanical seal

Installed period: 3 months

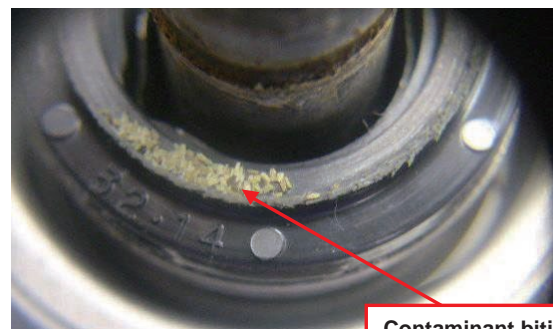

Contaminant biting

(3) Contaminant biting in mechanical seal

Travel distance: 42 km



Contaminant biting

Travel distance: 2,352 km

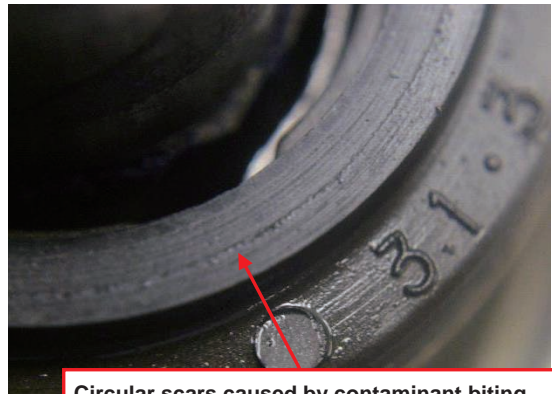
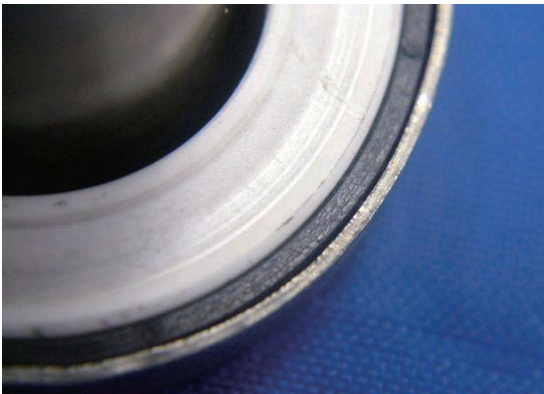

Circular scars caused by contaminant biting

(4) Burn and cracking of mating ring

Travel distance: 8,189 km



Burn and cracking occurred because operation was performed while lacking coolant after coolant level became low.

(5) Other (charging of leakage inhibitor)

Travel distance: 10,000 km



Adhesion of the leakage inhibitor to the pump chamber

Coolant leak and overheating

Coolant degradation

Oxidation and concentration dilution occur with the coolant as the use time extends, causing advancing of degradation. Although the anti-freezing performance hardly changes over time, decreases occur with the anti-rust and defoaming performances. As a result:

- Metal corrosion can generate biting contaminants, such as rust, in the mechanical seal sliding surface (seal surface), ultimately causing coolant leak from the drain hole.
- Propagation of metal corrosion and *cavitation can lead to coolant leak resulting from pitting as well as to overheating resulting from a loss of impeller. *Cavitation: See page 22

Ensure that the coolant concentration (30-50%) is appropriate for the climate of the region where the product is used.

(1) Rust biting in mechanical seal

Travel distance: 42 km



(2) Pitting in the body (through the hole reaching the drain hole and resulting in coolant leak)

Travel distance: 9,000 km



Drain hole

Occurrence of erosion by cavitation



(3) Pitting in the plug

Occurrence of erosion by cavitation



Plug

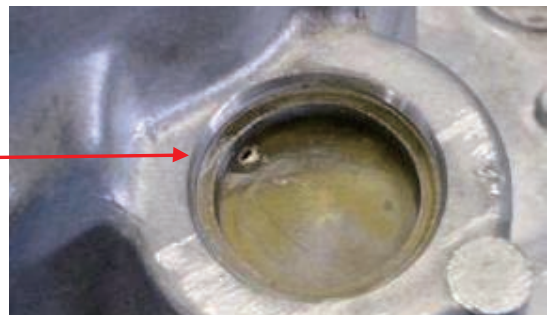

(4) Rust occurrence with the impeller Occurrence of corrosion and rust

Travel distance: 7,646 km



Installed period: 12 months

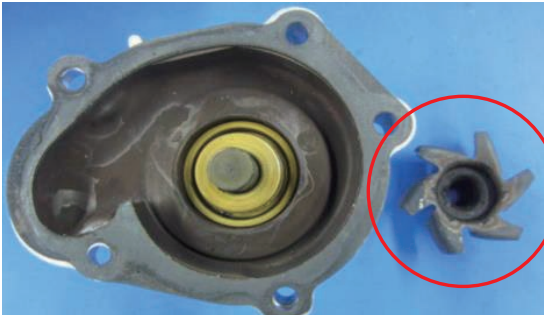

(5) Impeller corrosion and loss Occurrence of erosion by corrosion and cavitation

Installed period: 6 months

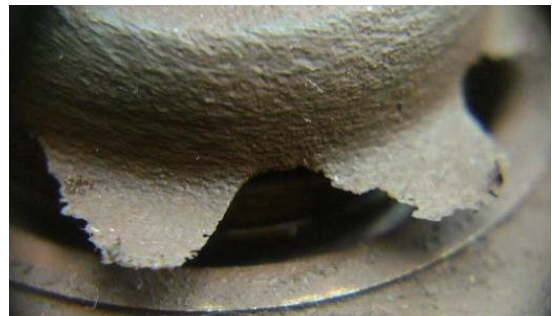

Installed period: 12 months

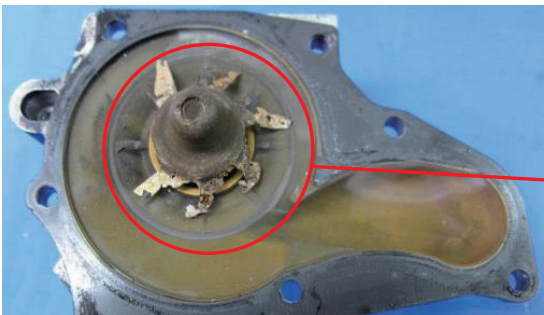

Coolant leak

Liquid gasket application failure

It is difficult to apply an appropriate amount of liquid gasket uniformly by hand, and as a result:

- Sealing performance of mounting surface can become inconsistent, and coolant may leak from the mounting surface.
- The liquid gasket protruding inside the pump chamber can fall and be caught in the mechanical seal sliding surface (seal surface), leading to coolant leak from the drain hole.

In addition, as the liquid gasket requires to be left approximately for 2 h after installation for drying without charging the coolant, it is recommended, considering the work efficiency, to perform mounting with only the gasket provided.

*When liquid gasket is used with the O-ring specification, the original sealing performance may not be attained, and coolant leak can result.

(1) Liquid gasket application failure (Application of liquid packing is not necessary)...See page 06

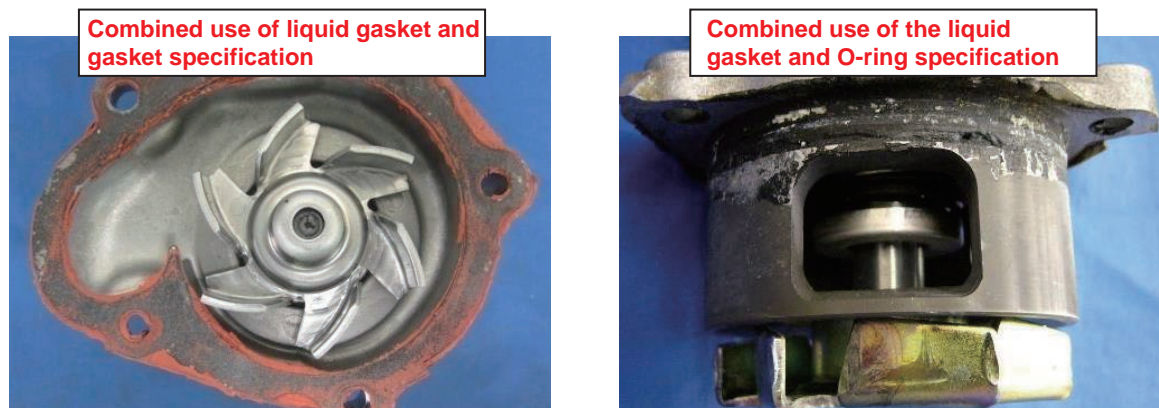

(2) Case example of liquid gasket biting into mechanical seal

Travel distance: 0 km

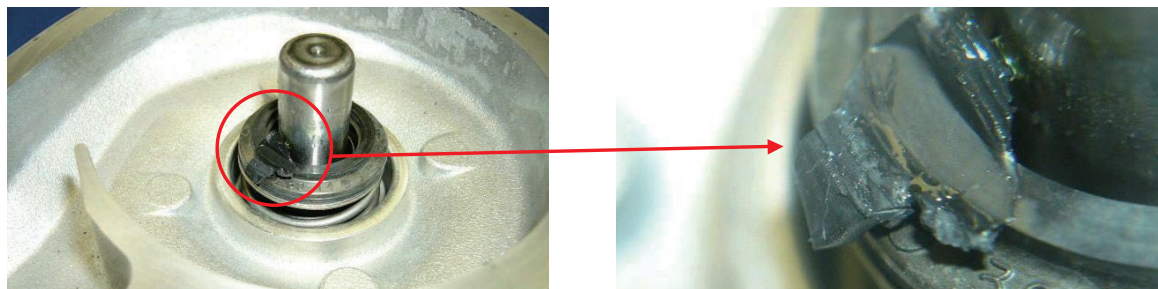

(3) Liquid gasket residue caught in mechanical seal

Travel distance: 284 km

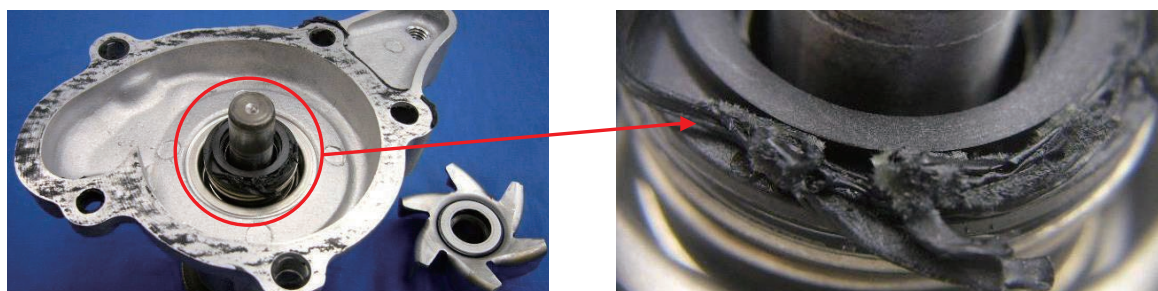

Abnormal noise, seal squeaking (high-frequency noise, low-frequency noise)

Stick-slip occurrence

Seal squeaking with mechanical seal is a phenomenon in which self-excited vibration caused by stick-slip between sliding surfaces (seal surface) becomes the source of noise. Stick-slip is caused by changes in sliding surface properties (e.g., carbon transfer, surface polishing, and uneven contact) occurring because of factors such as the starting of the engine in dry state (i.e., no coolant in the pump chamber), degraded coolant, and poor lubrication due to low concentration.

Stick-slip: A phenomenon in which the sliding surface repeats sticking (seizure) and slipping (slide)—the same in principle as the chattering noise occurrence with wipers.)

- (1) **Carbon transfer onto sliding surface** Components of the seal ring (fixed side) transferred to mating ring (rotating side)

Travel distance: 0 km

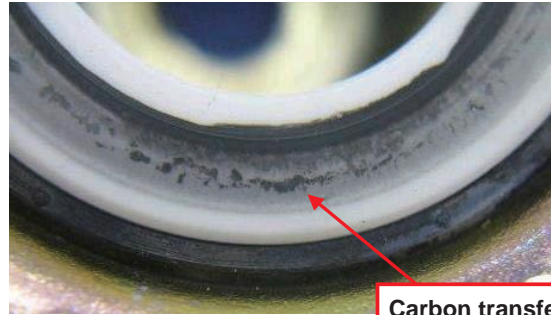

- (2) **Surface polishing of sliding surface** Surface polishing of the seal ring (fixed side) occurred due to seal surface lubrication fault, etc.

Travel distance: 0 km

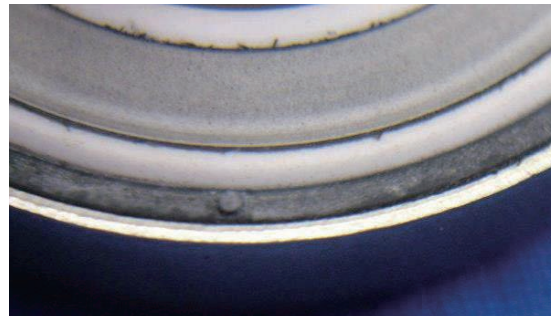
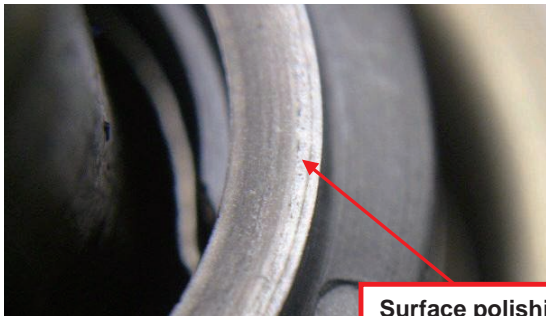

- (3) **Uneven contact of sliding surface** Increase in surface pressure occurred at a seal surface portion due to seal surface lubrication fault, etc.

Travel distance: 0 km

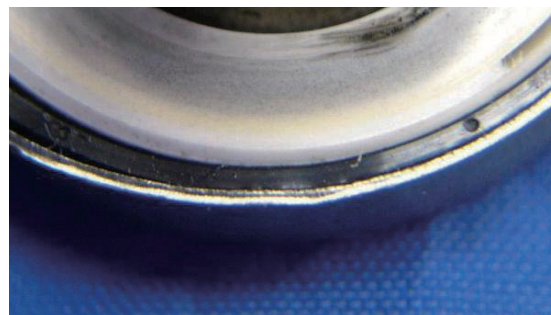
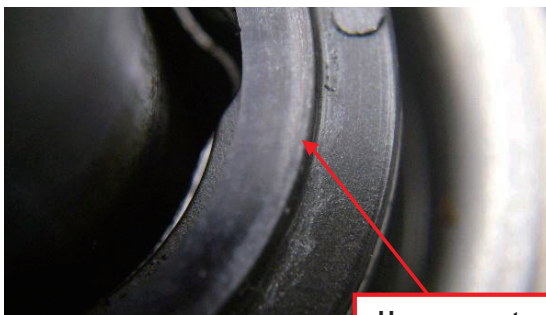

Abnormal noise (e.g., rumbling noise and croaking noise)

Bearing damage

Damage to the bearings will generate abnormal noise (e.g., rumbling noise and croaking noise). Possible causes for bearing damage:

- Coolant leak ⇒ Coolant intrusion into bearing ⇒ Degradation of bearing grease
- Excess belt tension
- Excessive vibration and other unfavorable responses due to fastening failure with mating part, deflection, or unbalance. As a result of excessive vibration, ***fretting** wear occurs to the contact surface and fastening parts (characterized by occurrence of cocoa-colored rust).

*Fretting: See page 22

(1) Bearing damage (coolant intrusion into bearing)

Installed period: 8 months



Installed period: 12 months



(2) Bearing damage (fretting wear on hub surface and hub axle)

Installed period: 2 months

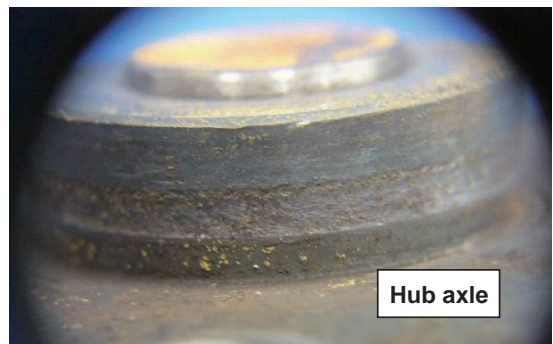
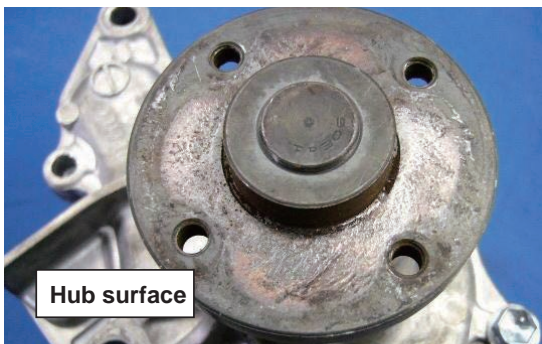

Travel distance: 5,149 km



Travel distance: 9,750 km



(3) Bearing damage (burns to shaft and ball)

Travel distance: 5,000 km

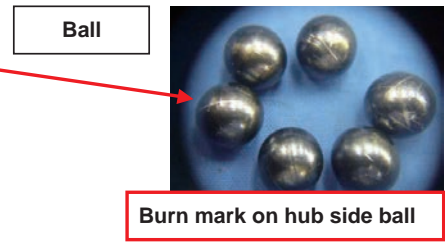
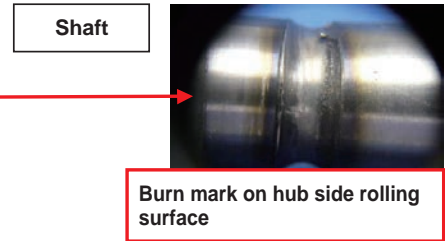
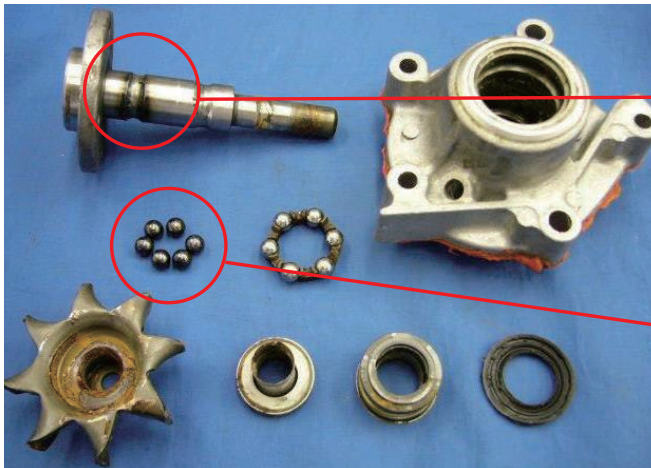

Installed period: 6 months

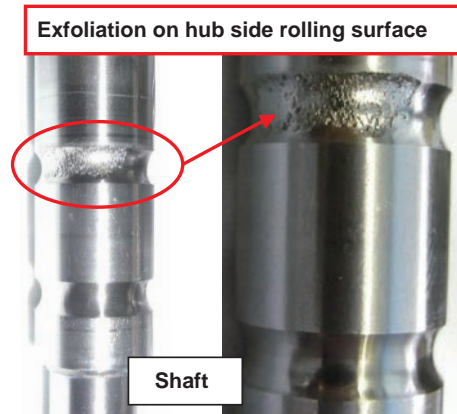
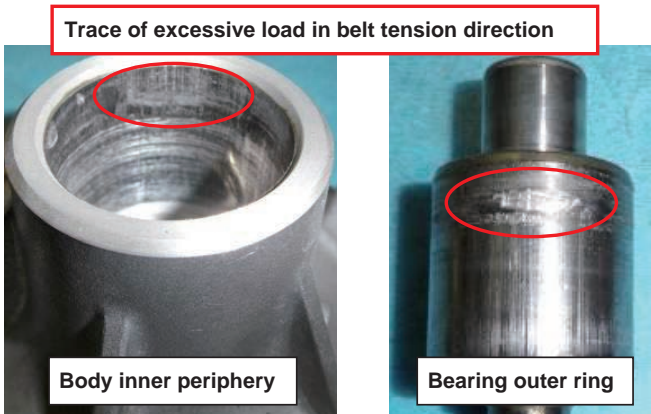

Defects associated with peripheral parts

Fan coupling

With the type in which the fan coupling is mounted at the water pump leading end, it is necessary to verify the occurrence of any problem in the coupling bearing.

- If staggering or sticking is recognized with the rotation of coupling bearing, or if there is damage to the bearing seal, replacement is required.
- Even when there is no abnormality, we recommend replacing the coupling if the travel distance of 100,000 km is exceeded.

If the use of a defective part is continued, excessive vibration by whirling can damage the pump.

(1) Body damage

Travel distance: 98 km



(2) Bearing shaft breakage

Installed period: 9 months



Glossary

LLC (long life coolant) For its roles, see page 01.

The main component of "LLC" is "ethylene glycol (structural formula: HO-CH₂-CH₂-OH)", and by adding rust preventive additives for various metals (iron-, aluminum-, and copper-series), the use life of the coolant is extended with additional capabilities, including rust prevention, oxidation prevention, and defoaming performance, provided in conjunction with the anti-freezing effect of ethylene glycol. Although the anti-freezing effect of ethylene glycol does not reduce, a periodic replacement is required because degradation occurs with additives.

Raw material	Effect	Degradation mode	Symptoms associated with degradation
Ethylene glycol	Anti-freezing effect	Practically no degradation over time	---
Additive	Rust prevention with various metals	Wearing by thermal load	Corrosion and rusting of each metal
	Antioxidation effect		Corrosion and rusting of each metal
	Defoaming effect		Cavitation occurrence

What is cavitation?

① It is a phenomenon caused by bubbles formed in the fluid, and by the process of pressure changes occurring in bubbles generated by the fluid flow. ② The bubble size changes corresponding to changes in pressure, which alters the volume of gas. The bubble goes through a process of gradually becoming smaller according to the pressure while repeatedly expanding and shrinking. ③ A bubble near a hard face, such as that of a propeller, sticks to the surface owing to viscosity and surface tension. Then, the surface of a bubble on the opposite side of the hard face starts sinking. ④ When the bubble breaks as a result of crashing into the surface with a jetting force, erosion is caused by the jet stream.

Image

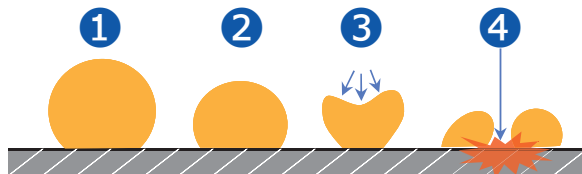

Marine propeller eroded by cavitation



What is fretting?

When there are repeated load applications to the fitting parts of mechanical elements such as railway car axle and turbine blades, or to the contacting areas between materials, a minute relative reciprocating slide movement occurs, leading to a surface damage, which produces reddish-brown abrasion powder, called fretting wear.

Furthermore, under continuous and repeated loading conditions, fatigue fracture can occur and propagate from the surface damage area, significantly reducing the fatigue strength of materials. Such fatigue phenomenon involving fretting on the contact surfaces is referred to as the fretting fatigue.

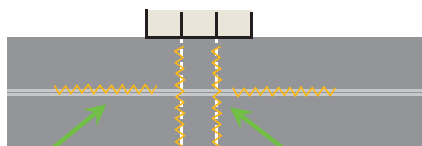

Fretting wear refers to the vibration wear that occurs when a contact load is applied between members by vibration or other reasons.
*The abrasion powder has a characteristic cocoa color (rust color).

Between hub surface and pulley



Between mounting bolt and hub thread

