

SHOWA

BFF Kit

BALANCE FREE FRONTFORK

For 2016 KAWASAKI ZX10R



Owner's Manual

 Read this manual carefully before operating this BFF Kit.

SHOWA

The best technology and the highest quality to meet every user's needs.

No. T574100-OME1

Introduction



Thank you for purchasing the SHOWA Balance Free Front Fork Kit (referred to as "the BFF Kit"). The BFF Kit is a suspension kit that provides the best performance and durability for public road riding for a "rider seeking a difference". It is designed with knowledge gained from the world's highest motor sports, Moto GP, World Superbike Championship, Dakar, etc. In 2015's World Superbike Championship, the winner of the world champion was riding the motorcycle equipped with the BFF and Balance Free Rear Cushion lite (BFRC® lite).

Installation of the BFF Kit, handling, and tuning are described in this Owner's Manual. Please read this manual carefully, and follow the described instructions. Please note that installation, handling, and tuning should be conducted in a dealership or controlled environment where there are technicians with special knowledge and skills. Make sure to change the spring, dust seal, and oil seal at a dealership or store specializing in installation. If conducted by the customer, it is not covered by the warranty.

The warranty is appended at the end of this manual. Please make sure to receive a warranty from a dealership where you purchased the product.

Handling this product properly

In this manual, items that need you to comply to prevent injuries on the user and other people and property damage, in addition to the correct installation are shown with the following "Symbols". Please understand what each "Symbol" means, and read this manual.

	It is the safety warning symbol. This symbol is used to call your attention when there is a danger for personal injury. Comply with the safety items specified after this symbol to prevent injury and accident that may cause death.
 WARNING	The symbol represents a content that if mishandled, "it may cause death or serious injury".
 CAUTION	The symbol represents a content that if mishandled, "it may cause injury or property damage".
Note	It describes points to pay attention, and focus when conducting service.

Safety Caution

Caution When Installing

 WARNING	<p>Special knowledge is required to replace the front fork. If someone without special knowledge performed installation, and the installation was improper, it may cause damage on the motorcycle and accident. Please make sure that replacement is conducted in a dealership or controlled environment where there are technicians with special knowledge and skills.</p>
	<p>If the product is installed on a modified motorcycle, it may cause function and performance deterioration. Install this product only on a motorcycle with genuine parts of its manufacturer.</p>

 CAUTION	<p>This product is a precision machine part. Deformation and dent from a drop, hammer, and shock may cause function and performance deterioration. When handling and installing the product, do not drop, hammer, and apply shock.</p>
	<p>If only one person handles the product, there may be a case that a motorcycle and parts cannot be held by himself/herself. Make sure 2 or more people work when removing and installing the product.</p>
	<p>When installing to a motorcycle, comply with the items described in the Service Manual provided by the motorcycle's manufacturer.</p>

Caution when Using

 WARNING	<p>High-pressure nitrogen gas is filled in this product. When disassembling and refilling nitrogen gas, the product may burst causing serious injury. If exposed to flames and puncture a hole, this product may burst causing serious injury. Replacement and discarding must be done by a specified dealership.</p>
---	---

 CAUTION	<p>There are recommended inspection items for this product to maintain its performance. If not inspected and defects are ignored, it may cause function and performance deterioration. When using, make sure to perform the inspection items described in this manual.</p>
	<p>Always use the oils specified by SHOWA. When unspecified oils are used, it may cause function and performance deterioration.</p>

Contents

Overview	1
Product Features	1
List of Specification	2
Recommended Inspection Items	2
Explanation of Icons Used in this Manual	3
Installation Method of the Product (Replacement from Standard Specification)	4
Measuring Vehicle Height Before Replacing	4
Installation	4
Measuring Vehicle Height After Replacing	5
Tuning Method	6
Spring Preload Tuning and Damping Force	6
• Spring Preload Tuning	6
• Damping Force Tuning	6
Available Option Parts	7
Replacement Method of the Spring	8
Removing	8
Adjusting Oil Level of Operation Oil	11
Installation	13
Replacement Method of the Dust Seal and Oil Seal	15
Removing	15
Installation	17
Troubleshooting	19

Overview

Product Features

The BFF Kit is a front fork product that enabled to reduce the fluctuations of pressure balance to the utmost limit by making the piston, damping valve, and sub tank independent, and the valve on the compression side and rebound side to the compact unit called the Plug Bolt COMP ⑤ which is placed on the axle holder.

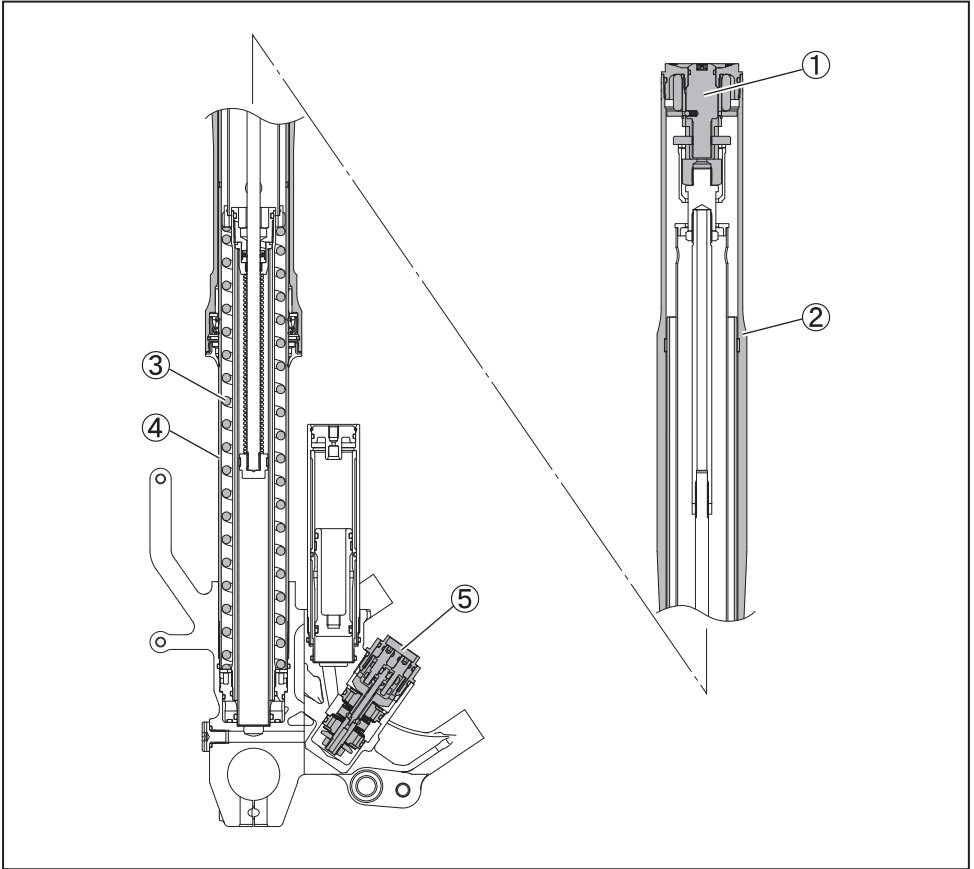

No.	Part Name	Reference Page
①	Fork Bolt COMP	Page 7, 8
②	Outer tube	Page 4, 6, 8, 12, 14, 15, 17
③	Spring	Page 6, 8, 10, 11, 13
④	Slide pipe	Page 15, 17, 19
⑤	Plug Bolt COMP	Page 1

Overview

List of Specification

		Kit	STD	
Assembly	Max. length/Min. length (mm)	745/615	739/619	
	Stroke (mm)	130	120	
	Slide pipe (Outer diameter) (mm)	43	43	
	Outer tube clamp (Diameter) Upper (mm)	50	50	
	Outer tube clamp (Diameter) Under (mm)	55	55	
	Outer tube length (mm)	486	480	
	Filled gas pressure (Mpa)	0.5	0.5	
	Axle hole (Inner diameter)	32	32	
Spring	Rate (N/mm)	10.25	11.25	
Rebound spring	Rate (N/mm) -ST (mm)	1.7-80	14-20	
Operation oil	Type of oil	SS47	SS47	
	Oil level (mm)	253	160	
Tuning reference position	Spring preload		Low + 10 clicks (Total: 30 clicks)	Low + 6 rotations (Total: 15 rotations)
	Damping force	Rebound side	Max -16 clicks	Max - 2.5 rotations
		Compression side	Max -25 clicks	Max - 3.5 rotations







Recommended Inspection Items

	Before riding	Semi-annually	Annually
Operation check of the front fork suspension	✓	✓	✓
Oil leakage of the front fork suspension	✓	✓	✓

Overview

Explanation of Icons Used in this Manual

In this manual, the following icons are displayed in illustrations for inspection and disassembling service to proceed smoothly.

Icon	Explanation
	Specify the tightening torque.
	It shows the press fitting part. Press fit using an adequate adapter.
	It shows a part to clamp. To prevent deformation of a part, always clamp on the specified part.
	A location to apply Liquid O-Ring #400.
	A location to apply molybdenum grease.
	Replace with a new part.

Installation Method of the Product (Replacement from Standard Specification)



WARNING

Please make sure that installation is conducted in a dealership or controlled environment where there are technicians with special knowledge and skills.

When replacing the front fork, conduct tuning of the motorcycle posture with the following ways.

Measuring Vehicle Height Before Replacing

1. While placing a motorcycle on the ground, measure the distance from the axle shaft of the front wheel to the top bridge, and record the value.
2. Measure above while a rider is on the motorcycle, and record the value.
3. Measure above by jacking up the motorcycle and the front wheel is dropped completely, and record the value.

Installation

1. Remove the front fork on the motorcycle.

[Note]

For the removing method of the front fork, refer to the service manual of the motorcycle manufacturer.

2. Install the BFF Kit to the motorcycle.
 - Install the upper end of the outer tube in the BFF Kit to be 7 mm projection dimension from the top bridge upper face.

[Note]

For the installation procedure and tightening torque of each bolt, refer to the service manual of the motorcycle manufacturer.

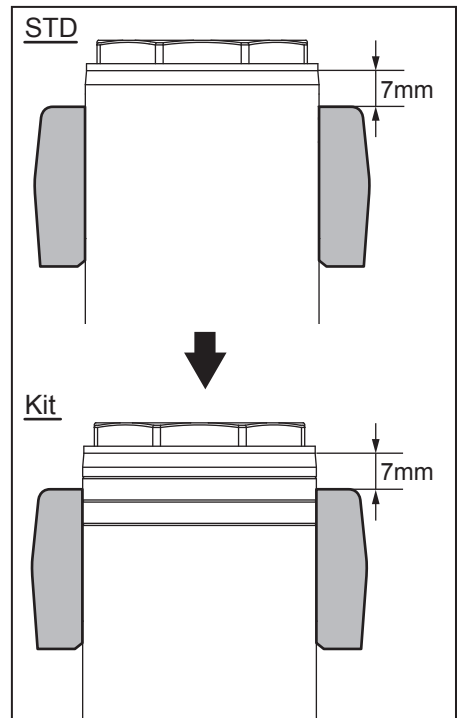

Installation Method of the Product (Replacement from Standard Specification)

3. Install the axle shaft.
- For installation of the axle shaft, refer to the service manual of the motorcycle manufacturer.
 - Tighten the axle holder bolt ① with the specified torque after applying molybdenum grease on the screw part.

Tightening torque: 20 N·m

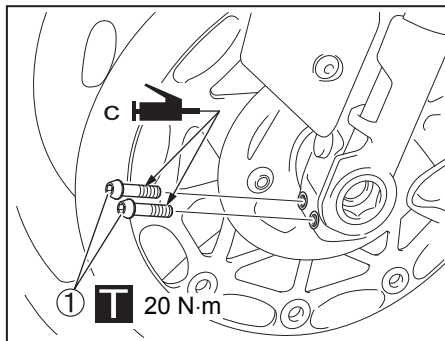

 CAUTION	Tighten the axle holder bolt ① with the specified torque after applying molybdenum grease.
---	---

Measuring Vehicle Height After Replacing

 WARNING	After replacement, the caster angle of the front fork is changed from the pre-replacement state. If ridden in this condition, it is very dangerous because the motorcycle behavior may be unstable and the brake performance may change. Before riding, make sure to tune the motorcycle posture.
---	--

Measure similarly before replacement, and adjust the spring preload to be the same value before replacement. (Refer to page 6.)

 CAUTION	<ul style="list-style-type: none">• When lowering the vehicle height, adjust within the range that each part of the motorcycle does not interfere with the BFF Kit in the most compressed condition.• Conduct vehicle height tuning with the spring preload, and do not change the projection amount of the outer tube.• If setting problem is not resolved, contact your nearest dealership that sells SHOWA products.
---	--

Tuning Method

Spring Preload Tuning and Damping Force

Perform spring preload tuning and damping force tuning of the BFF Kit following the procedure below.

⚠ CAUTION

- Always perform tuning in the position that a clicking feeling can be felt. When tuned between clicking positions, it can cause shifted setting during riding.
- Always tune evenly on the right and left front fork.

● Spring Preload Tuning

Attach a hexagonal wrench (6 mm) on the center of the fork bolt COMP to perform tuning.

[Note]

- The standard is 10 clicks clockwise from the position that is turned all the way on the Low side.
- 1 click changes 0.5 mm preload amount.

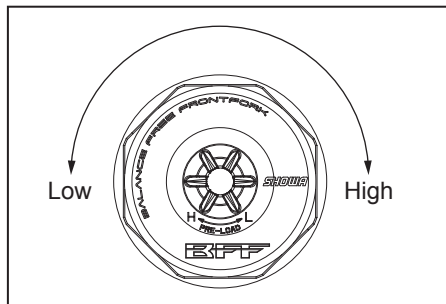

● Damping Force Tuning

Adjust the COM and REB on the plug bolt by turning with a hexagonal wrench (3 mm).

COM: Compression side

REB: Rebound side

⚠ CAUTION

Do not force to turn from the position that stops lightly for the Soft side and Hard side. It may cause internal damage.

[Note]

- The standard on the compression side is 25 clicks counterclockwise from the position that is turned all the way on the Hard side.
- The standard on the rebound side is 16 clicks counterclockwise from the position that is turned all the way on the Hard side.

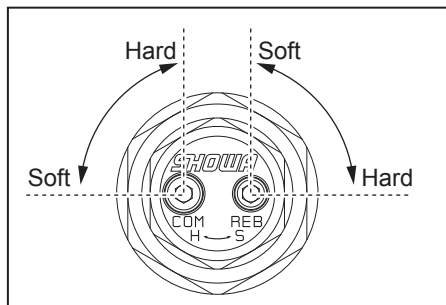

Tuning Method

Available Option Parts

To widen the vehicle height tuning and setting change, a spring for replacement is available as the optional part. For purchasing, contact the specified dealership.

Rate (N/mm)	Specification
11.25	Hard
10.75	Medium hard
10.25	Standard
9.75	Medium soft
9.25	Soft

Replacement Method of the Spring

Replace the spring with the following procedure.



WARNING

Make sure the replacement is performed at a dealership or store specializing in installation. If performed by the customer, the warranty will be void.

Removing

1. Remove the BFF Kit from the motorcycle.

[Note]

For the removing method of the front fork, refer to the service manual of the motorcycle manufacturer.

2. Loosen the fork bolt COMP ② to free from the outer tube ①.
 - Clamp the part [C] of outer tube ①, and loosen the fork bolt COMP ② using a tool.

[Note]

While the front fork is attached to the motorcycle, the fork bolt COMP ② can be loosened. Refer to the service manual of the motorcycle manufacturer.

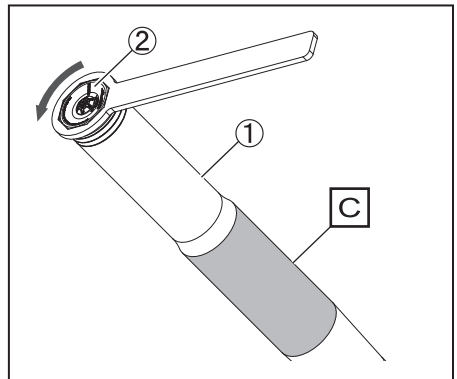

3. Lower the outer tube ① to the bottom.

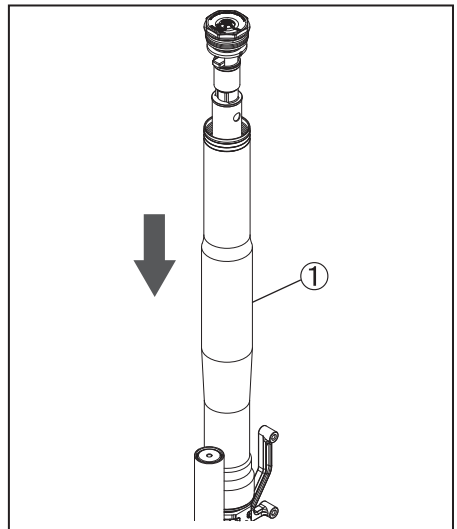

Replacement Method of the Spring

4. Remove the fork bolt COMP ② and collar ③.
- Hook and fix a 17 mm wrench ① on the across flat part of the joint metal ④, and turn the fork bolt COMP ② with a tool to remove the fork bolt COMP ②.

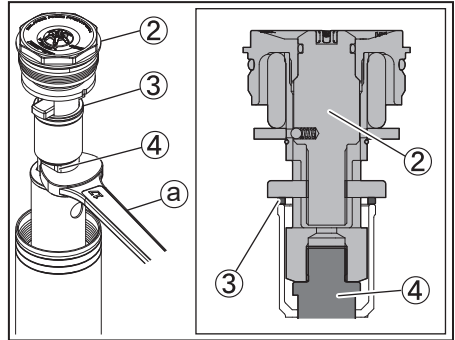

5. Attach the tool ⑥ to the joint metal ④.
- Use the one with a M12 x 1.25 female screw is cut on the end of a round rod with approx. 15 mm in diameter. The length should be 200 mm or more.

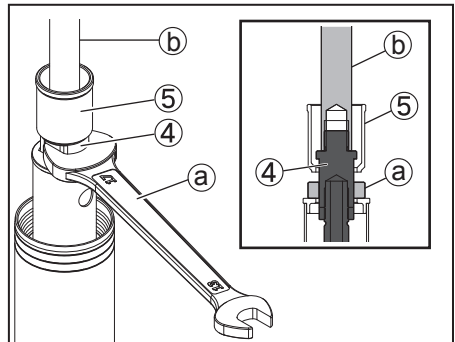

6. Pull up the tool ⑥ to remove the wrench ①, and remove the tool ⑥ and slider ⑤.

Replacement Method of the Spring

- 7. Remove the spring collar COMP ⑥ and the spring ⑦.
 - Use a tool that the end of a wire is bent to the hook shape, and hook it to remove.

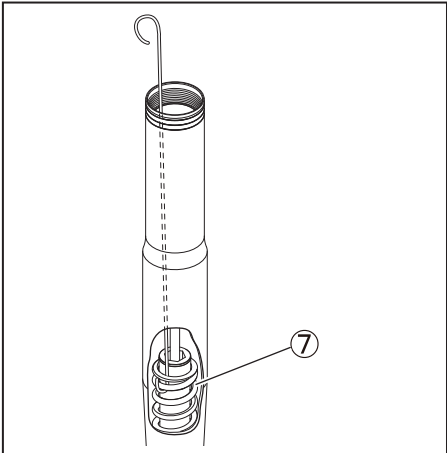
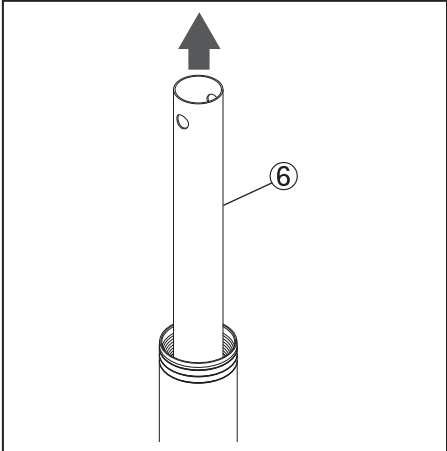

Replacement Method of the Spring

Adjusting Oil Level of Operation Oil

[Note]

- Because a small amount of oil is attached on the removed parts, after disassembling, the oil face in the front fork is lower than the reference value.
- Whilst only the spring is in place, conduct an oil face adjusting.

1. Enter the spring ①.

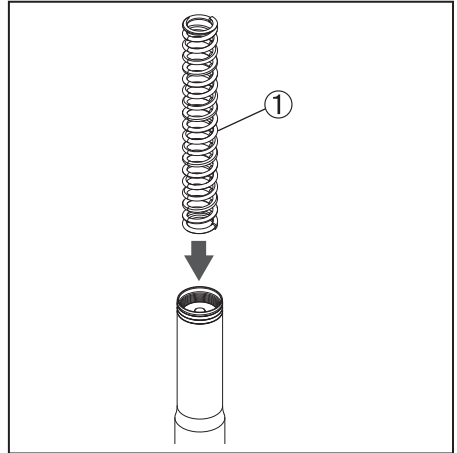

Replacement Method of the Spring

- 2. Fill operation oil.
- 3. Using an oil face adjustment tool, adjust the operation oil face.

Specified oil: SHOWA SS47
Operation oil face height (A): 253 mm

 CAUTION	<ul style="list-style-type: none">• Conduct oil face adjustment while only the spring ① is in.• Perform while the outer tube ② is lowered all the way.
---	---

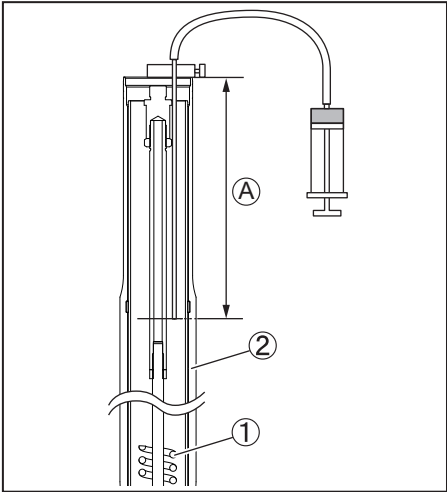
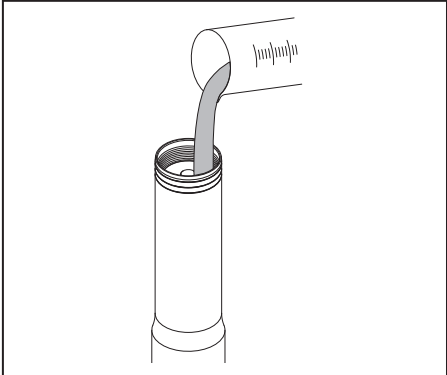

Replacement Method of the Spring

Installation

1. Attach the tool ⑥ to the joint metal ①.

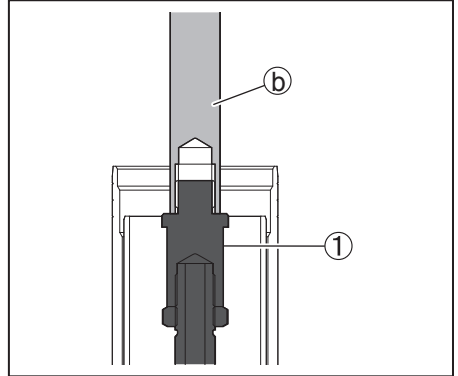

2. Attach the spring collar COMP ② and the slider ③.

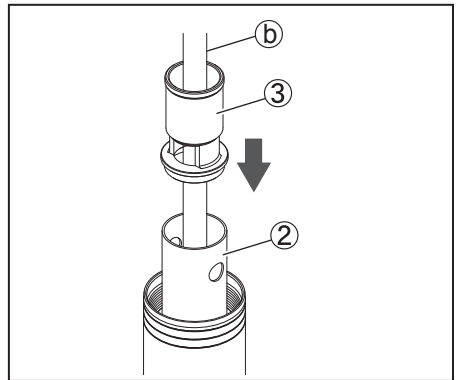

3. Pull up the tool ⑥, and hook a 17 mm wrench ④ on the across flat part of the joint metal ①.

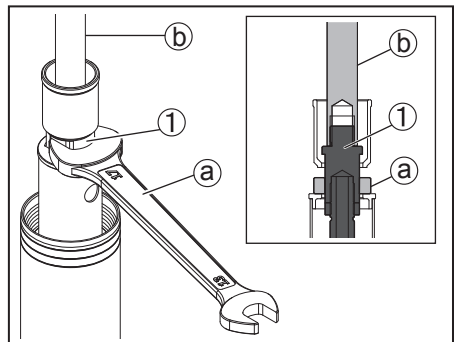

4. Remove the tool ⑥.

Replacement Method of the Spring

5. Install the collar ④ and fork bolt COMP ⑤ to the joint metal ① with the specified torque.
- On the fork bolt COMP ⑤ and the outer diameter of O-ring ⑥, apply Liquid O-Ring #400.

Tightening torque: 25 to 30 N·m

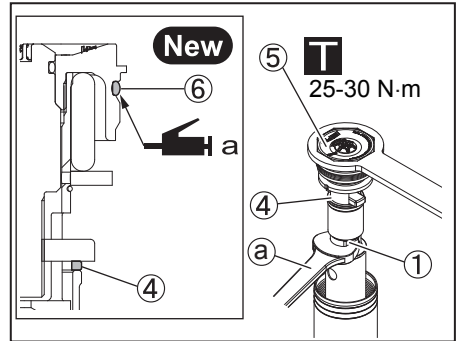

6. Clamp the part **C** of outer tube ⑦, and attach the fork bolt COMP ⑤ using a tool with the specified torque.

Tightening torque: 30 to 40 N·m

 CAUTION	Clamp not to damage or deform the outer tube.
---	--

7. Install the BFF Kit to the motorcycle. For installation, refer to Installation Method of the Product (Replacement from Standard Specification) (Page 4).

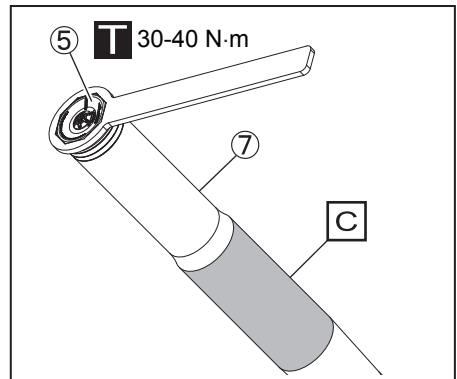

Replacement Method of the Dust Seal and Oil Seal

Replace the dust seal and oil seal with the following procedure.



WARNING

Make sure the replacement is performed at a dealership or store specializing in installation. If performed by the customer, the warranty will be void.



CAUTION

Be cautious not to damage the parts.

Removing

For the removing of oil seals, see the removing procedure of the spring replacement method 1 to 7 (Page 8 to 10).

1. Discharge operation oil.
 - Tilt the BFF Kit, and discharge oil.

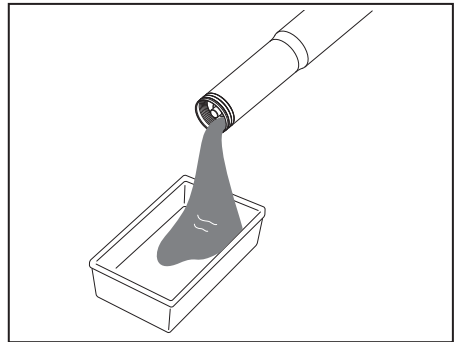

2. Extract the outer tube ① from the slide pipe.
3. From the outer tube ①, remove the dust seal ②, stopper ring ③, oil seal ④, and oil seal spacer ⑤.

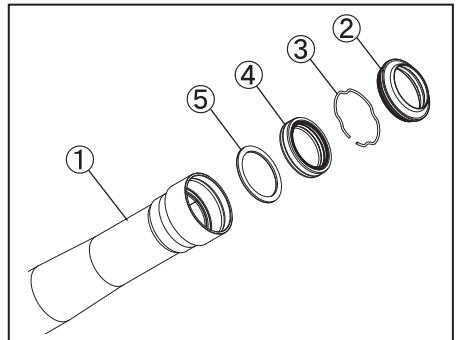

Replacement Method of the Dust Seal and Oil Seal

4. Remove the guide bush ⑥.
- Attach the tool ③ that removes the outer race of bearings to the guide bush ⑥.
 - Use an adequate shaft to strike the tool ③ remove the guide bush ⑥.

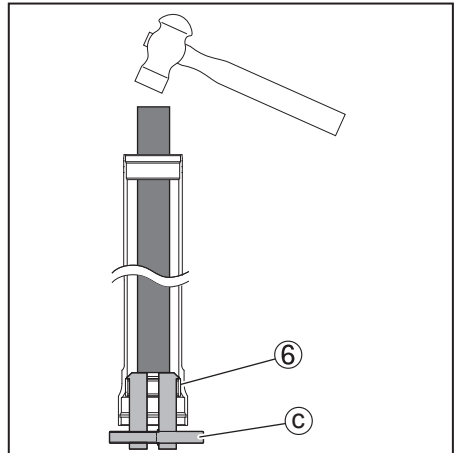
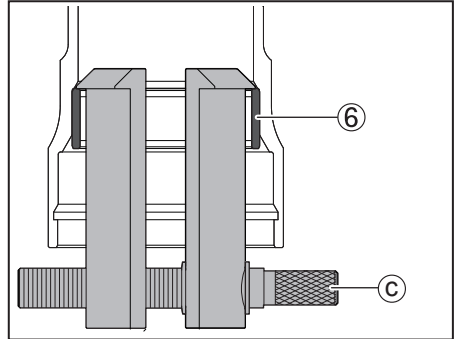

Replacement Method of the Dust Seal and Oil Seal

Installation

1. Attach the tool ㉓ for seal damage prevention to the slide pipe ①, and from the tool ㉓ side, attach in the order of the dust seal ②, stopper ring ③, and oil seal ④.
 - Apply the Liquid O-Ring #400 overall inside the lip for the dust seal ② and oil seal ④.

 CAUTION	Apply a thin layer of the Liquid O-Ring #400 overall inside the dust seal ②.
---	---

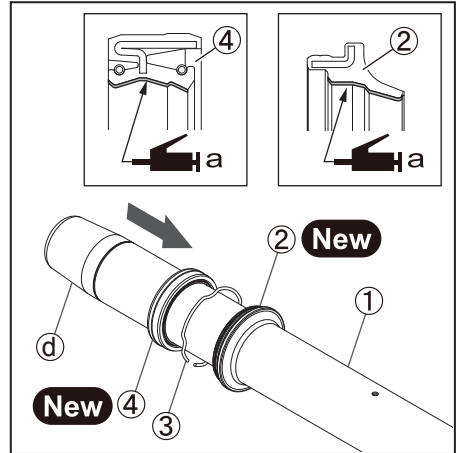

2. Attach the oil seal spacer ⑤ and guide bush ⑥.

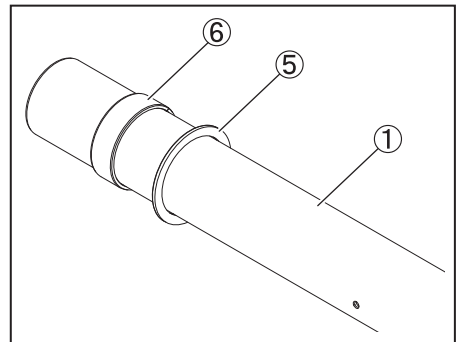

3. Insert the slide pipe ① to the outer tube ⑦.
4. Press fit the guide bush ⑥ and oil seal spacer ⑤ to the outer tube ⑦ with the installer tool ㉔.

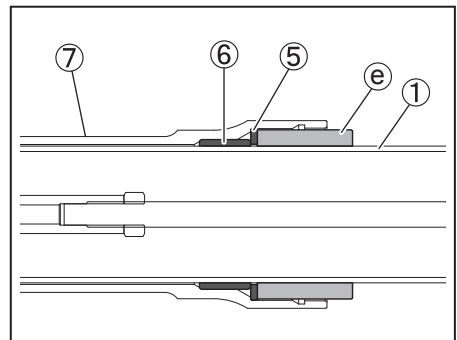

Replacement Method of the Dust Seal and Oil Seal

- 5. Press fit the oil seal ④ to strike the oil seal spacer ⑤, and place the stopper ring ③ to the groove ⑧ firmly.

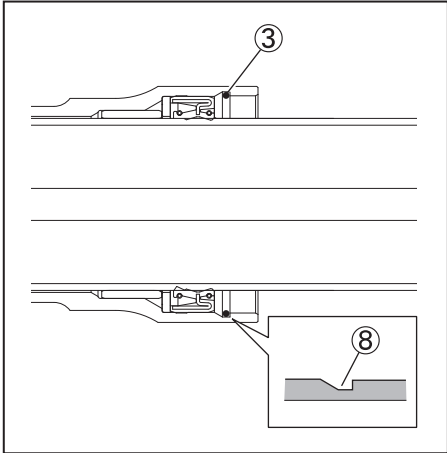
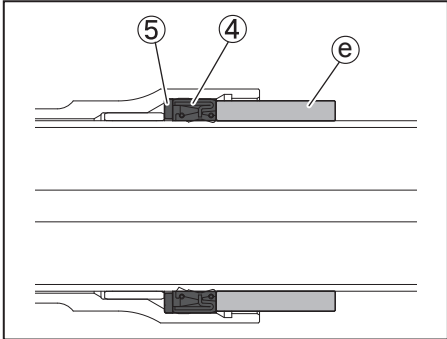

- 6. Using the installation tool (f), press fit the dust seal (2) to adhere the end of the outer tube (7). For the following procedure, refer to Adjusting oil level of operation oil and Installation in the Replacement Method of the Spring (Page 11 to 14).

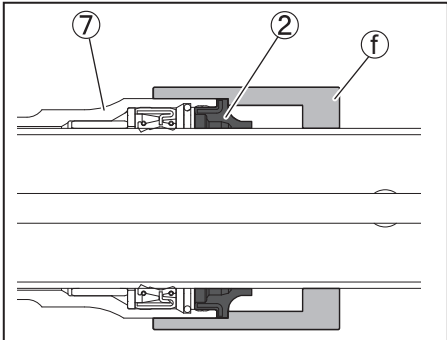

Troubleshooting

Symptom	Cause	Measures
The suspension operation is soft.	Inadequate damping force tuning.	Tune suspension.
	The viscosity coefficient of the operation oil is low.	Replace oil (SHOWA genuine oil).
	The operation oil amount is low.	Adjust the oil amount.
	Setting of spring.	Replace spring.
	The gas filling pressure is low.	Check at the dealership.
The suspension operation is hard.	Bent slide pipe.	Check at the dealership.
	The viscosity coefficient of the operation oil is high.	Replace oil (SHOWA genuine oil).
	The operation oil amount is high.	Adjust the oil amount.
	The gas filling pressure is high.	Check at the dealership.
Noise in the front fork.	Damage.	Check at the dealership.

MEMO

Warranty

To Dealership

Please make sure a customer reads and agree with the warranty regulations, and enter information in the box below.

If sold without filling out the information, the warranty shall not be effective.

The warranty shall not be applied to sensible symptoms (sound during adjusting, color tone changes due to lighting, etc.) acknowledged as having no effect on the product functions.

The warranty shall not be applied to a product lacking a manufacturing engraved seal serving as the warranty engraved seal.

Manufacturing engraved seal			
Customer	Name		
	Address		
	Phone		
	E-mail		
Purchased date		Dealership name	
Year:	Month:		
Warranty period (From the purchased date)		Address	
6 months		Phone	
		E-mail	

If information is not filled in the box above, the warranty shall not be applied. Please make sure to fill it all.

If information is not filled in the box above, please contact the dealership a product is purchased promptly.

This warranty shall not be reissued. Please store in a safe place.

This document guarantees warranty application (free repair) on the contents specified in this document.

Manufacturer: SHOWA CORPORATION

1-14-1, Fujiwara-cho, Gyoda, Saitama 361-8506, Japan

<http://www.showa1.com>

Distributor: K-Tech Suspension Limited

Rawdon Business Park, Marquis Dr, Swadlincote, Derbyshire DE12 6EJ UK.

TEL +44 (0) 1283559000

<http://www.ktechsuspension.com/>

Warranty regulations

1. If this product fails to operate properly during the specified warranty period as used under normal condition following the cautions in the owner's manual, appended labels on the product, etc., please take the product and this warranty to a dealership you purchased the product, present the warranty, and request for warranty application.
2. The warranty shall not be applied in the following cases even in the specified warranty period.
 - When the spring, dust seal, and oil seal are changed by the customer.
 - Functional problems generated in the product's normal operation are not present.
Normal operation noise and some oil permeation on the oil seal itself (if there are no performance issue).
 - Change in riding comfort and feelings generated based on the product's characteristics.
 - When the product is used for racing (includes circuit driving)
 - Failure and damage due to improper usage, and invalid modification and repairs
 - Failure and damage due to accident, fall, and drop.
 - Failure and damage due to fire, salt, natural disaster like earthquake, and external factors.
 - When the warranty is not presented.
 - When the manufacturing engraved seal of this document does not match the product's manufacturing engraved seal.
 - When required information on the warranty is missing or rewritten.
 - Failure and damage due to installation to a model the product is not intended for.
 - Failure and damage due to connected other devices.
 - Failure caused from using parts, oil, etc. not specified by SHOWA.
 - Replacement of consumable parts.
 - Failure and damage due to the customer's usage environment, maintenance and management methods (scratches due to skipped stones, rust, color change, etc., from riding).
3. To have a repair service on this product, please request in the product unit condition.
Please note any cost to make it the product unit condition (cost for installation, removal, and other labor) is not covered by this warranty.
Also, on-site repair service shall not be provided on this product even during the specified warranty period.
4. Please understand that warranty regulations are applied on the product unit only, not any other devices to be connected.
5. Please note that all inconvenience and losses (phone call fees, towing fees, replacement products, loaner vehicles, compensation for absence from work, sales loss, etc.) caused from having a warranty repair shall not be covered under any circumstances.
6. Please note that our company is not liable for any loss and damage outside the manufacturer warranty of your vehicle through installation of this product.

Balance Free Front Fork Kit Owner's
Manual

©SHOWA CORPORATION, June,
2016, All rights reserved.

Any reprinting or unauthorized use
without the written permission of
SHOWA CORPORATION is prohib-
ited.

Printed in Japan